



RANDOLPH AUSTIN COMPANY

www.RandolphAustin.com

Operations Manual

Pump Series: 250

Model #250-PHO

- 250 Pump Head
- Tubing Sizes:
 - 1/16" ID x 3/16" OD
 - 1/4" ID x 3/8" OD

Randolph Austin Company
2119 FM 1626
Manchaca, Texas 78652
(512) 282-1590

8 7 6 5 4 3 2 1

THE INFORMATION CONTAINED IN THIS DRAWING IS THE SOLE PROPERTY OF Randolph Austin Company. ANY REPRODUCTION IN PART OR WHOLE WITHOUT THE WRITTEN PERMISSION OF Randolph Austin Company IS PROHIBITED.

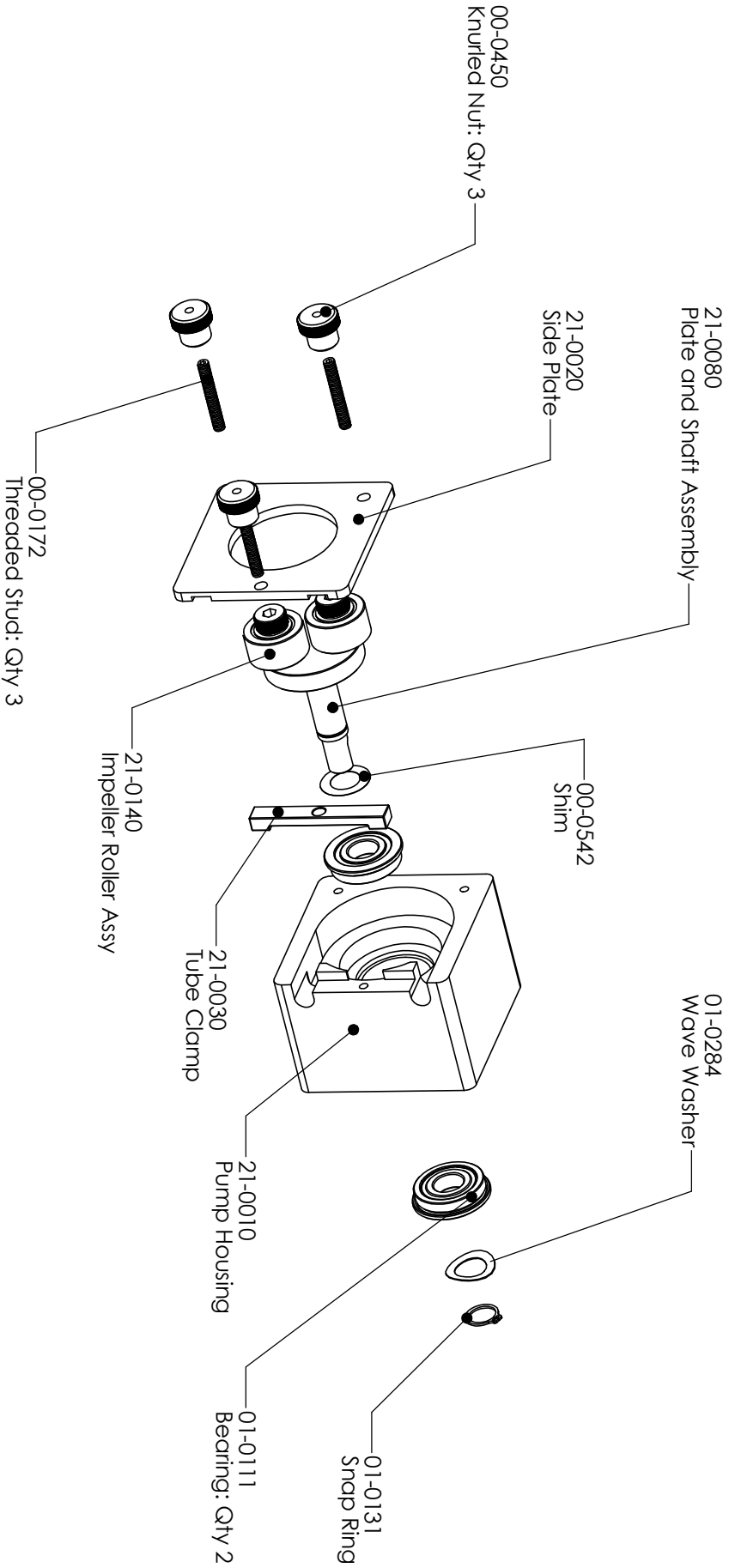

ITEM NO.	PART OR IDENTIFYING NO.	NOMENCLATURE OR DESCRIPTION	MATERIAL SPECIFICATION	QTY REQD
PARTS LIST				
		Randolph Austin Company		

UNLESS OTHERWISE SPECIFIED DIMENSIONS ARE IN INCHES TOLERANCES ARE:
 REACTIONS DECIMALS ANGLES
 +/- 1/64 .XX +/- .01 + 1
 .XXX +/- .005

CAD GENERATED DRAWING, DO NOT MANUALLY UPDATE

APPROVALS DATE

DRAWN CHECKED

RESP ENG MFG ENG

FINISH ---

MATERIAL ---

DO NOT SCALE DRAWING

QUAL ENG

Exploded View: 250 Pump

Rev	Description	By	Date
-	New Print	-	09-10-02
-	Wave Washer Added	-	03-28-12

APPLICATION	USED ON	DO NOT SCALE DRAWING	QUAL ENG	SCALE	CAD FILE:	SHEET	OF
APPLICATION	USED ON	DO NOT SCALE DRAWING	QUAL ENG	A	250-PHO	1	8

Randolph Austin Company

Peristaltic Pumps

WHY CHOOSE A PERISTALTIC PUMP?

Peristaltic pumps work by using a flexible tubing inside a raceway, which is alternately compressed by a set of rotating rollers. This flexing action insulates the materials being transferred from the moving parts of the pump. The advantages are important when transferring sterile solutions, abrasives, inks or any other fluid, which would ordinarily contaminate or destroy the internal components of a pump. Because of the action of the Randolph pump, it is an excellent choice for shear sensitive fluids and applications where fluid metering is necessary.

PERFORMANCE PARAMETERS

Several factors such as viscosity, pressure, speed, pump configuration, and tubing selection, influence the flow rate of a Randolph pump. These factors must be considered to determine the selection of a pump.

Fluids with increased viscosity will result in reduced flow rates. Careful consideration needs to be made to the distance and height of the pump relative to fluids being pumped, especially if they are viscous. The further the pump is from the source, the greater the flow loss.

The discharge pressure capabilities of the Randolph pump will vary with the type and size of tubing selected as well as the operating conditions of the pump. Excessive discharge pressure may rupture tubing or reduce the effective tubing life.

Tubing selection must consider the fluid compatibility, temperature, and pressure, which the pumping application will see. It is recommended that the tubing be immersed in the fluid to be pumped for a minimum of 24 hours as a method of determining chemical compatibility. However, there is no guarantee that tubing which passes a "soak" test will perform in the same manner inside the pump. The soak test, while providing valuable information, does not replicate the dynamic situation inside the pump.

WHY YOU SHOULD CHOOSE A RANDOLPH PERISTALTIC PUMP

Randolph pumps are manufactured to exacting tolerances with high quality materials. The rugged construction of the Randolph pump makes it an ideal choice for applications where trouble free performance is necessary.

With over forty years' experience, in peristaltic pumps, Randolph Austin Company has a proven track record of value and service to our customers.

STANDARD CONSTRUCTION

Randolph pumpheads are available in a variety of material constructions. Models 250, 500, 610, and 750 are machined from aluminum housings and use stainless steel internal components for corrosion and wear resistance. The model 880 pump is machined from an aluminum casting, and uses plated steel components for its impeller plate and shaft.

STAINLESS STEEL MODELS

Randolph Austin Company offers the 615 and 755 model pumps in a 316 stainless steel housing. This material is well suited for washdown applications. Model 615 and 755 pumps have the same performance characteristics as the standard model 610 and 750 pumps respectively.

PLASTIC PUMP HEADS.

The 300 and 400 series pumps housings are made from polycarbonate. These pumps offer the O.E.M. cost effective, quality units to incorporate into their design. The 300 series pump is designed to mount directly of motor and can be configured in a variety of forms. The 400 series pump is a panel mount pump with a standard three-impeller roller yoke and hinged side cover. The 400 series is the newest pump in the Randolph Austin catalog.

General Characteristics of Randolph Austin Tubing Materials

Cilran™ is made from a thermoplastic elastomer that possesses exceptional chemical resistance to acids and bases. **Cilran™** has low gas permeability; good flex fatigue resistance and meets USP Class VI specifications. Ideal for use in many laboratory applications, it may be used in place of silicone for some applications. **Cilran™** is translucent white in color.

Povinal™ is a polyvinyl alcohol based tubing which is excellent for use in applications with aliphatic, aromatic and chlorinated hydrocarbon solvents. **Povinal™** has good flex fatigue resistance and is suitable for many industrial applications. It may be used as a substitute for fluoroelastomer polymers in some applications. Not recommended for use with water or solutions containing concentrations of water. Pump tubing is teal in color. Transfer tubing is amber.

Vytex™ is a clear flexible polyvinyl tubing ideal for general-purpose usage in applications with dilute aqueous solutions (both acids and alkali's), and for food and beverage usage. Strong acid solutions may be used with **Vytex™** for short intervals, but should be flushed with water after use. The smooth surface allows for easy flushing and cleanup for food and beverage applications. **Vytex™** is a durable, high flex tubing with a Shore "A" durometer of 60 allowing a long life expectancy for continuous flexing where peristaltic pumps are used.

Prothane II™ is transparent, aqua blue, polyester polyurethane tubing that exhibits excellent abrasion resistance, has good low temperature properties and is resistant to ozone and oxidation. **Prothane II™** exhibits an excellent resilience to continuous flexing and impacting experienced in peristaltic pumps. Along with these exceptional features **Prothane II™** exhibits good hydrolic stability, good oil and fuel resistance, and high tensile and tear strength. **Prothane II™** is resistant to diesel fuel, kerosene, motor oil, mild solvents, aromatic hydrocarbons, gasoline, and concentrated acid and alkaline solutions.

E-D Plex™ is multi-purpose tubing that is ideally suited for applications that range from transferring paint, ink, acids, and bases. Some oil and hydrocarbons will work with **E-D Plex™**, but should be tested before use. Combining the environmental resistance of EPDM with the chemical resistance of chloroprene, **E-D Plex™** possesses similar elastomeric performance found in more expensive vulcanized rubber, while still maintaining high flex fatigue resistance. **E-D Plex™** has been proven very successful in peristaltic pump applications where continuous flexing is required.

HOW TUBING IS INSERTED IN THE PUMP

1. Turn power off. Remove side plate and tubing clamp. Remove existing tubing by manually turning rollers while gently tugging on the tubing.
2. Manually move rollers so that they are horizontal in relation to the base of the pump. Carefully insert tubing through the top tubing clamp section and the top of the pump housing. Manually turn the rotor in a counter clockwise direction until the roller begins to compress the tubing and begin feeding the tubing behind the bottom roller.
3. When the pump has moved ½ turn the tubing should be in a compressed state at the 9:00 o'clock position.
4. Return the side plate and tubing clamp to the pump. Tighten the knurled nuts on the side plate and tube clamp.

Tubing sizes and capacities of the Randolph Pump:

Pump Series	Tubing Size
250	.062" (3/16") ID x .187" (3/16") OD
250	.125" (1/8") ID x .250" (1/4") OD
300	.250" (1/4") ID x .437" (7/16") OD
400	.250" (1/4") ID x .437" (7/16") OD
510	.187" (3/16") ID x .375" (3/8") OD
510	.250" (1/4") ID x .437" (7/16") OD
610, 615, 620	.375" (3/8") ID x .625" (5/8") OD
610, 615, 620	.500" (1/2") ID x .750" (3/4") OD
750	.625" (5/8") ID x .937" (15/16") OD
750	.750" (3/4") ID x 1.062" (1 1/16") OD
880	.750" (3/4") ID x 1.125" (1 1/4") OD
880	1.00" (1") ID x 1.500" (1 1/2") OD

Randolph Austin Company

Tubing Chemical Resistance Chart

Code indicates the percentage weight gain or loss after 24 hours immersion in the fluid.

(B) Best = 1-4%, (G) Good = 5-10%, (F) Fair = 11- 15%, (P) Poor = 16%+

The data contained herein are based on tests conducted on representative samples and are considered accurate. The results should indicate liquids that could be used with the tubing. However no guarantee is given or implied regarding the application of this data to the safe use of the tubing. It is suggested that the purchaser conduct tests to determine if this material is suited to this application.

	Cilran™	ED-Plex™	Povinal™	Prothane II™	Vytex™
<u>Aqueous Solutions</u>					
Water	B	B	P	B	B
Sodium Chloride (Saturated)	B	B	F	B	B
Aluminum Sulfate	B	B	P	B	B
<u>Acids & Bases</u>					
Sulphuric Acid (66° Be)	B	B	P	G	B
Acetic Acid, Glacial	B	P	P	P	F
Hydrochloric Acid (30° Be)	B	B	P	P	G
Nitric Acid (40° Be)	B	B	P	P	G
Sodium Hydroxide (50% sol.)	B	B	P	B	B
Ammonia Hydroxide	B	B	P	B	B
<u>Aliphatic Hydrocarbons</u>					
Diesel Fuel	P	P	B	G	G
Naptha	P	P	B	G	G
Mineral Oil	P	P	B	G	B
<u>Aromatic Hydrocarbons</u>					
Toluene	P	P	B	P	P
Xylene	P	P	B	P	G
<u>Chlorinated Solvents</u>					
Trichloroethylene	P	P	B	P	P
Carbon Tetrachloride	P	P	B	P	P
Methylene Chloride	P	P	B	P	P
<u>Ketones</u>					
Acetone	B	B	F	P	P
Methyl Ethyl Ketone (MEK)	G	G	F	P	P
<u>Esters</u>					
Amyl Acetate	P	B	F	P	P
Butyl Acetate	P	B	F	P	P
Ethyl Acetate	P	F	F	P	P
<u>Alcohol</u>					
Butyl Alcohol	G	G	P	G	B
Isopropyl Alcohol	G	B	F	B	B
Methyl Alcohol	B	B	F	G	B
Ethyl Alcohol (90%)	B	B	G	G	G
<u>Glycol</u>					
Ethylene Glycol	B	B	G	B	B
Glycerine	B	B	G	B	B
<u>Vegetable Oil</u>					
Safflower Oil	B	B	B	B	G

MATERIAL SAFETY DATA SHEET

Randolph Austin Company - 2119 F.M. 1626 – Manchaca, TX 78652

PRODUCT NAME: Tube Lube
PRODUCT CODE: N/A

Date: Nov-02-2001

SECTION I

HAZARDOUS INGREDIENTS

<u>Ingredient</u>	<u>Percent</u>	<u>TLV</u>
None (at this time)		

SECTION II

HEALTH HAZARDS

Threshold Limit Value: N/E

Effect of Overexposure

Eyes: Prolonged exposure may cause eye irritation.

Skin: Prolonged exposure may cause skin irritation

Inhalation: UNK

Ingestion: Harmful if swallowed in sufficient quantities.

First Aid

Eyes: Flush with plenty of water for 15 minutes while lifting eyelids to insure entire eye surface is washed.

Skin: Wash with soap and water

Inhalation: UNK

Ingestion: Consult physician.

Other Information: None

SECTION III

SPECIAL PROTECTION INFORMATION

Respiratory Protection: No special respiratory protection is required under normal situations. During the generation of large quantities of oil mist, use a MSHA/NIOSH approved respirator.

Ventilation Requirement: No special ventilation is required

Protective Clothing:

Eyes: Normal Protection against foreign substances – safety goggles.

Skin: Chemical resistant gloves should be used

Additional Protective Measures: Eye Wash Station and safety shower should be provided

SECTION IV

FIRE AND EXPLOSION HAZARD DATA

Flash Point (Method): 540 ° F (c.c.)

Flammable Limits (% Volume in Air): N/A

Upper: N/A **Lower:** N/A

Extinguishing Media: Water – Fog, Foam, Carbon Dioxide and Dry Chemical

Special Fire Fighting Procedures: Standard fireman's body protection. Self-contained breathing apparatus must be used to protect from products of combustion.

Unusual Fire and Explosion Hazards: Keep away from heat, sparks and open flame

512-282-1590 - Fax (512) 280-0678 - 24 Hour Emergency 800-424-9300 / 703-527-3887

MATERIAL SAFETY DATA SHEET

Randolph Austin Company - 2119 F.M. 1626 – Manchaca, TX 78652

SECTION V

PHYSICAL DATA

Boiling Point: N/A	Specific Gravity (Water =1): 0.959	Vapor Pressure (MM HG): UNK
Evaporation Rate: N/A	Solubility in Water: UNK	Vapor Density (Air =1): N/A
pH: UNK	Weight per Gallon: 7.95 lbs	Percent Volatile by Volume: N/A

Appearance and Odor: Light Yellow, Oily, No Apparent Odor

SECTION VI

REACTIVITY DATA

Stability: Stable

Incompatibility: N/A

Conditions to Avoid: Keep from contact with oxidizing materials.

Hazardous Decomposition Products: Product of incomplete combustion can include CO, CO₂ and dense smoke.

Hazardous Polymerization: Will not occur.

SECTION VII

SPILL AND LEAK PROCEDURES

Steps to be taken if material is released or spilled: Soak up spill with sand, earth or sawdust. Flush with detergent and water.

Waste Disposal Method: Dispose of in accordance with Federal, State and local regulations

SECTION VIII

D.O.T. SHIPPING INFORMATION

Proper Shipping Name: None

Hazard Class: None

ID Number: None

Label Requirements: None

Other Information: None

SECTION IX

ADDITIONAL INFORMATION

This information may be of importance to you:

Precautions to be taken in handling and storing: Store in closed containers, protect from moisture and foreign matter. Keep away from heat and excessively warm areas.

Other precautions: Do not transfer to unmarked containers.

Conditions to Avoid: Keep from contact with oxidizing materials

N/A = Not Applicable

N/D = Not Determined

N/E= Not Established

UNK = Unknown

Date Issued: 03/07/1986

Date revised: 11/01/2001

512-282-1590 - Fax (512) 280-0678 - 24 Hour Emergency 800-424-9300 / 703-527-3887