

THE INFORMATION CONTAINED IN THIS DRAWING IS THE SOLE PROPERTY OF Randolph Austin Company ANY REPRODUCTION IN PART OR WHOLE WITHOUT THE WRITTEN PERMISSION OF Randolph Austin Company IS PROHIBITED.

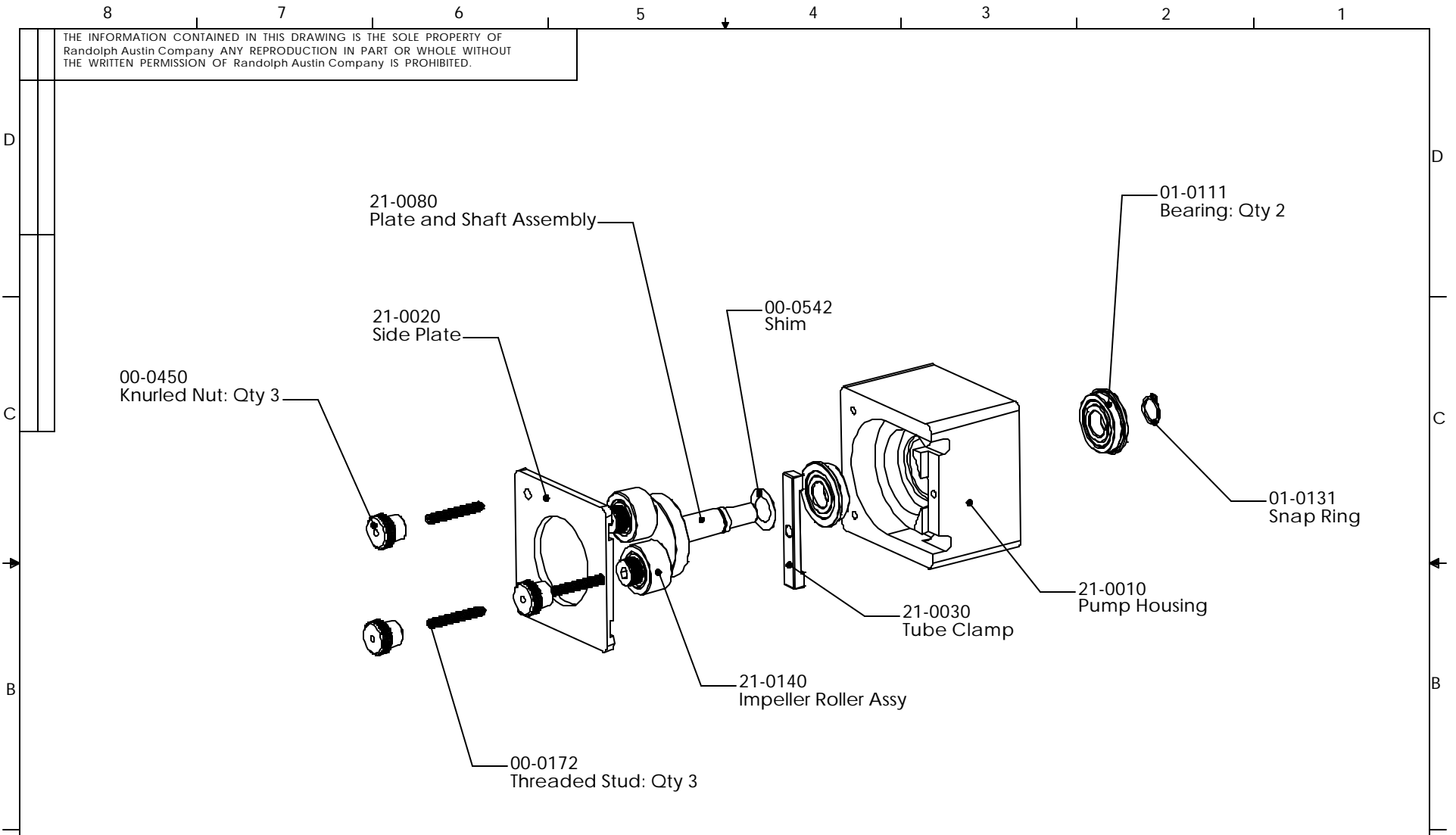

ITEM NO.	PART OR IDENTIFYING NO.	NOMENCLATURE OR DESCRIPTION	MATERIAL SPECIFICATION	QTY RECD
PARTS LIST				
UNLESS OTHERWISE SPECIFIED DIMENSIONS ARE IN INCHES TOLERANCES ARE:		CAD GENERATED DRAWING. DO NOT MANUALLY UPDATE		Randolph Austin Company
FRACTIONS DECIMALS ANGLES +/- 1/64 .XX +/- .01 + 1 .XXX +/- .005		APPROVALS	DATE	
MATERIAL --		DRAWN		Exploded View: 250 Pump
FINISH --		CHECKED		
NEXT ASSY USED ON		RESP ENG		
APPLICATION		MFG ENG		
DO NOT SCALE DRAWING		QUAL ENG		SIZE A
		SCALE	CAD FILE:	DWG. NO. 250-PHO
				REV.
				SHEET OF

Rev	Description	By	Date
	New Print		09-10-02

REVISIONS		DATE	APPROVED
ZONE	REV.	DESCRIPTION	

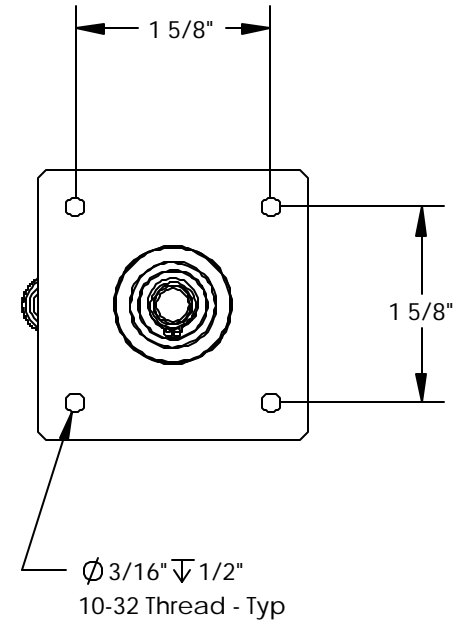
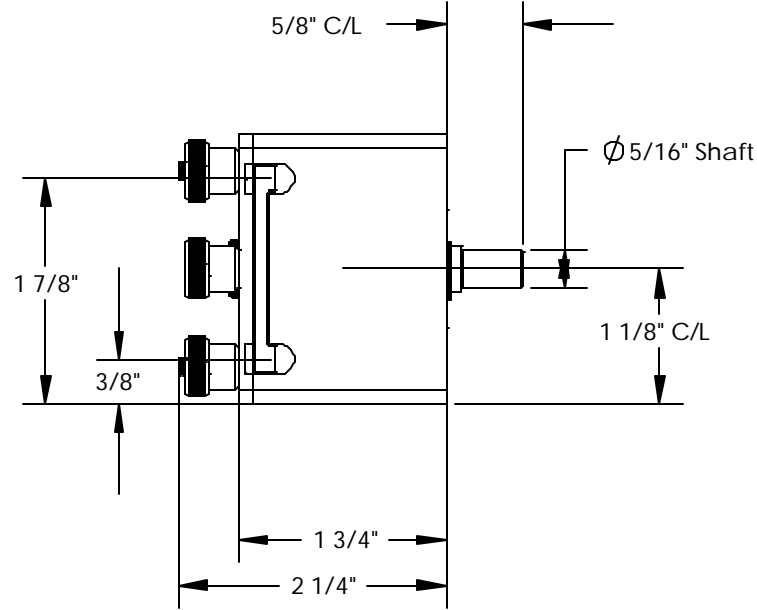
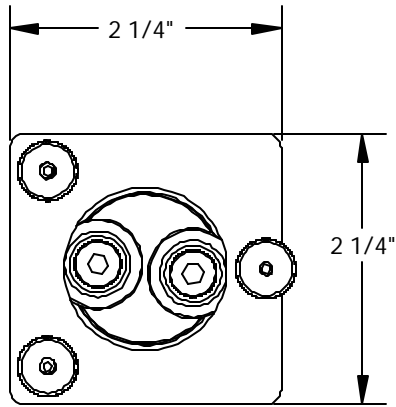

**PROPRIETARY AND CONFIDENTIAL**  
 THE INFORMATION CONTAINED IN THIS DRAWING IS THE SOLE PROPERTY OF Randolph Austin Company. ANY REPRODUCTION IN PART OR AS A WHOLE WITHOUT THE WRITTEN PERMISSION OF Randolph Austin Company IS PROHIBITED.

		DIMENSIONS ARE IN INCHES TOLERANCES: FRACTIONAL $\pm 1/64$ ANGULAR: MACH $\pm 1$ TWO PLACE DECIMAL $\pm .01$ THREE PLACE DECIMAL $\pm .005$		NAME	DATE	Randolph Austin Co
		MATERIAL --		DRAWN		
		FINISH --		CHECKED		250 Pump Head Mounting Dimensions
NEXT ASSY	USED ON			ENG APPR.		
APPLICATION		DO NOT SCALE DRAWING		MFG APPR.		
				Q.A.		
				COMMENTS:		SIZE <b>A</b>
						DWG. NO. 250-PHO-MD
						REV.
						SCALE:1:1
						WEIGHT:
						SHEET 1 OF 1