

		REVISIONS		
ZONE	REV.	DESCRIPTION	DATE	APPROVED
	A	Motor Assembly added - Corrected Belt Guard Assy No. Added p/n for rubber feet	09/16/04	

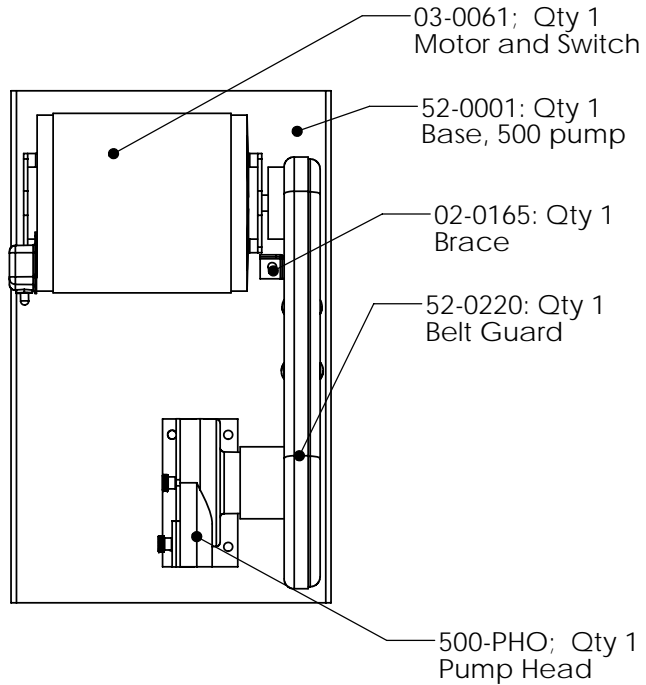

Specifications:

- 1: 430 Rpm, Single Speed, Non-Reversing
- 2: Power Requirements: 115 VAC, 60 Hz, 1 Ph, 5.7 Amps

B.O.M - Items Not Shown

- 04-0481: Pulley, 1 1/2", Motor
- 00-0491: Pulley, 6", Pump
- 00-0582: "V" Belt

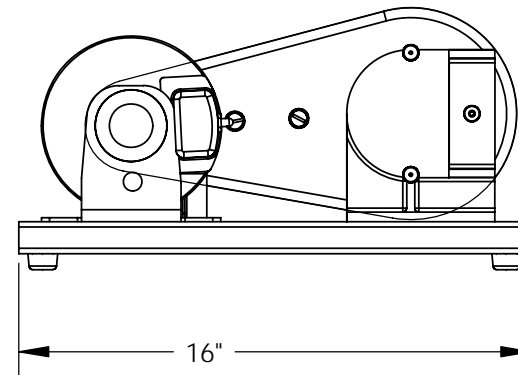
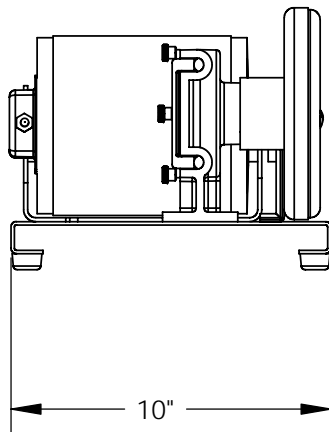

PROPRIETARY AND CONFIDENTIAL
 THE INFORMATION CONTAINED IN THIS DRAWING IS THE SOLE PROPERTY OF Randolph Austin Company. ANY REPRODUCTION IN PART OR AS A WHOLE WITHOUT THE WRITTEN PERMISSION OF Randolph Austin Company IS PROHIBITED.

			NAME	DATE	Randolph Austin Co 500-100 Assembly Print
			DRAWN		
			CHECKED		
			ENG APPR.		
			MFG APPR.		
			Q.A.		
			COMMENTS:		
		MATERIAL	--		
		FINISH	--		
NEXT ASSY	USED ON				
APPLICATION		DO NOT SCALE DRAWING			
SIZE	DWG. NO.			REV.	
A	500-100			A	
SCALE:1:8	WEIGHT:			SHEET 1 OF 1	