

		REVISIONS			
ZONE	REV.	DESCRIPTION	DATE	APPROVED	

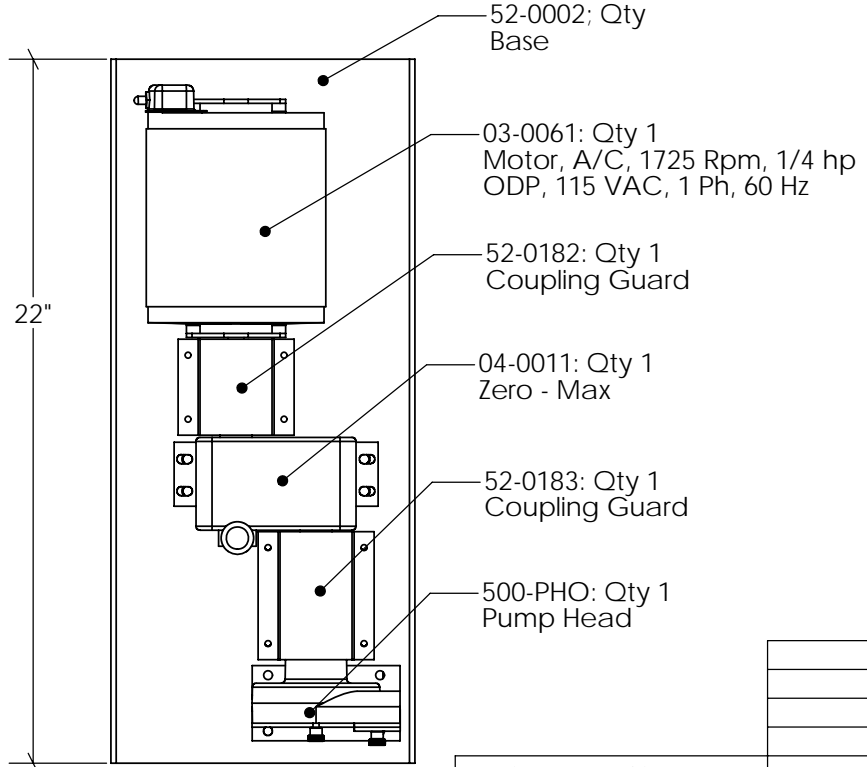
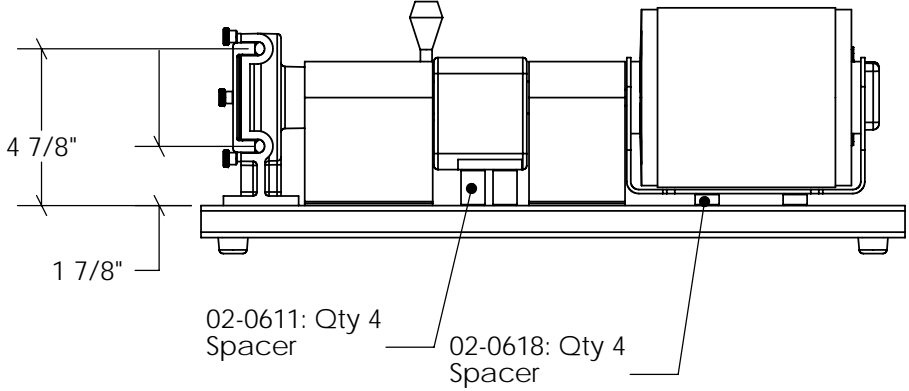
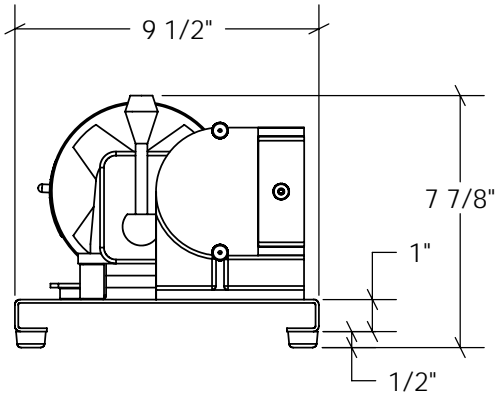

B.O.M. - Materials Not Shown  
 00-0312: Qty 2 - Coupling 3/8"  
 00-0322: Qty 2 - Coupling 1/2"  
 00-0380: Qty 2 - Rubber "Spyder"

**PROPRIETARY AND CONFIDENTIAL**  
 THE INFORMATION CONTAINED IN THIS DRAWING IS THE SOLE PROPERTY OF Randolph Austin Company. ANY REPRODUCTION IN PART OR AS A WHOLE WITHOUT THE WRITTEN PERMISSION OF Randolph Austin Company IS PROHIBITED.

		DIMENSIONS ARE IN INCHES TOLERANCES: FRACTIONAL ± 1/64 ANGULAR: MACH ± 1 TWO PLACE DECIMAL ± .01 THREE PLACE DECIMAL ± .005		NAME	DATE
		MATERIAL			
		FINISH			
NEXT ASSY	USED ON				
APPLICATION		DO NOT SCALE DRAWING			

<b>Randolph Austin Co</b>			
500-101: Assembly Layout			
SIZE	DWG. NO.	REV.	
<b>A</b>	500-101		
SCALE: 1:1	WEIGHT:	SHEET 1 OF 1	