

THE INFORMATION CONTAINED IN THIS DRAWING IS THE SOLE PROPERTY OF THE RANDOLPH AUSTIN CO.. ANY REPRODUCTION IN PART OR WHOLE WITHOUT THE WRITTEN PERMISSION OF THE RANDOLPH AUSTIN CO. IS PROHIBITED.

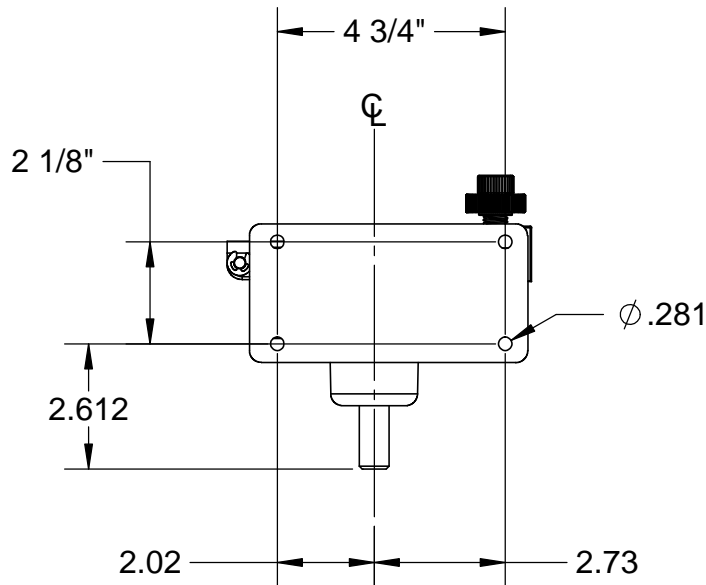
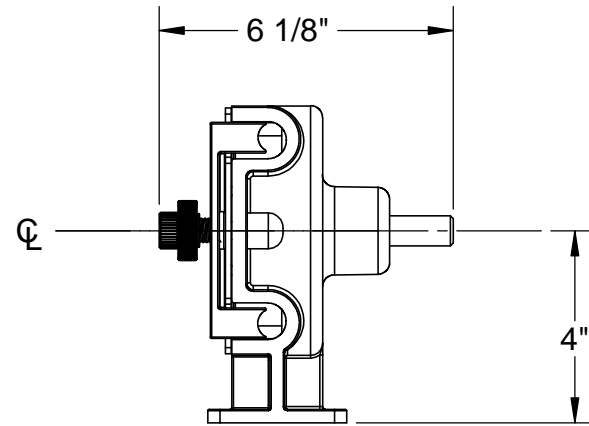
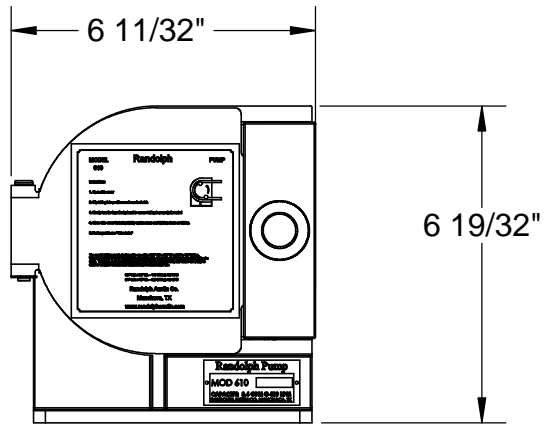

Starting Torque and Shipping Dim				
Part Number	Starting Torque - In-lbs	Net Weight	Gross Weight Lbs	Shipping Dim
610-PHO	27	6.3	8.0	10" x 10" x 10"
610-PH3	25.2	6.9	8.6	10" x 10" x 10"

UNLESS OTHERWISE SPECIFIED  
 DIMENSIONAL TOLERANCES ARE:  
 FRACTIONS DECIMALS ANGLES  
 MILLIMETERS:  
 N/A ±.127 ±.5°  
 INCHES:  
 ±1/64 ±.005 ±.5°

CAD GENERATED DRAWING.  
 DO NOT MANUALLY UPDATE



2119 FM 1626  
 MANCHACA TX. 78652  
 (512) 282-1590

APPROVALS	DATE
DRAWN	2/6/2018
CHECKED	
RESP ENG	
MFG ENG	
QUAL ENG	

### 610-PHO & 610-PH3 Mounting Dimensions

SIZE	DWG. NO.	REV.
A	610-PHO	
SCALE	CAD FILE: 610-PHO	SHEET 1 OF 3

NEXT ASSY	USED ON
APPLICATION	

MATERIAL **SEE NOTES**  
 FINISH **SEE NOTES**  
 DO NOT SCALE DRAWING

THE INFORMATION CONTAINED IN THIS DRAWING IS THE SOLE PROPERTY OF THE RANDOLPH AUSTIN CO.. ANY REPRODUCTION IN PART OR WHOLE WITHOUT THE WRITTEN PERMISSION OF THE RANDOLPH AUSTIN CO. IS PROHIBITED.

ITEM NO.	PART NUMBER	Default/QTY.
1	61-0010	1
2	01-0113	2
3	01-0133	1
4	61-0050	1
5	00-0601	1
6	61-0140	2
7	61-0097	1
8	00-0532	1
9	61-0080	1

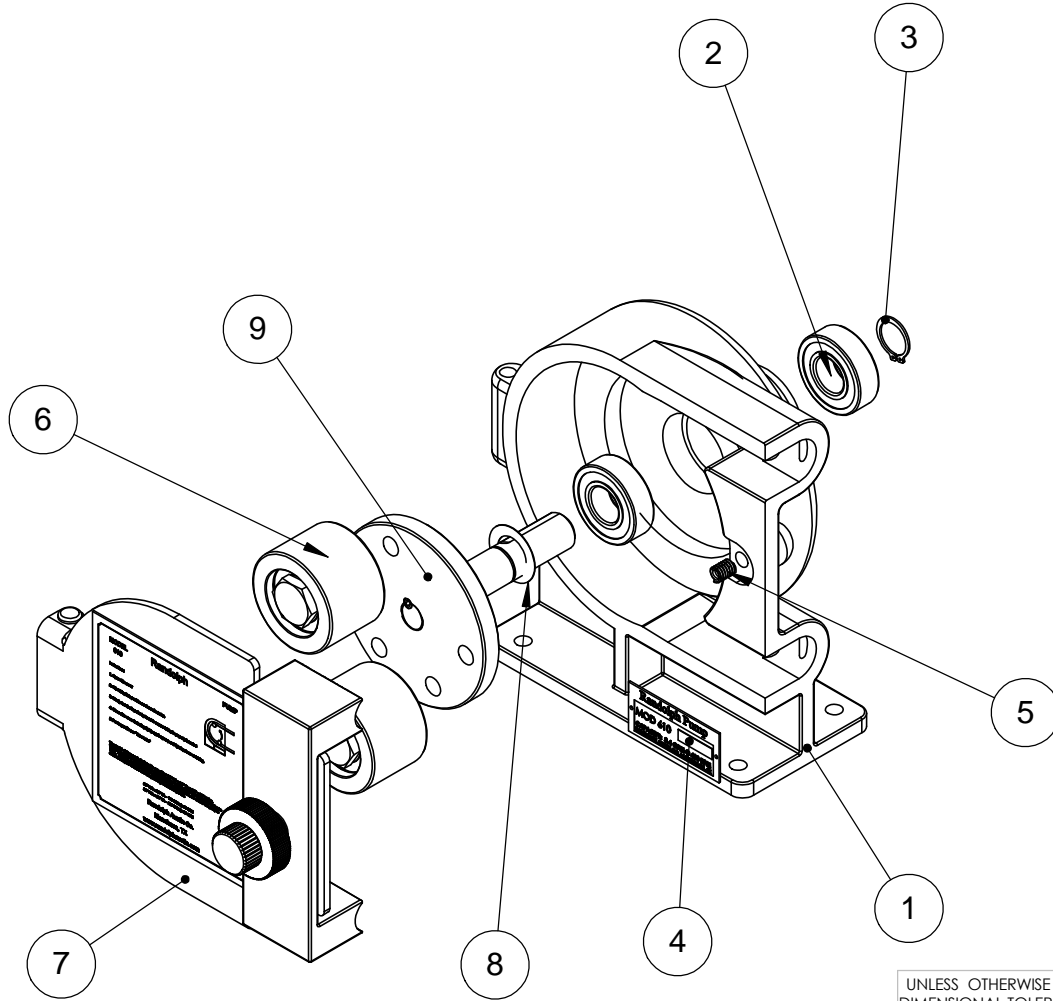

UNLESS OTHERWISE SPECIFIED  
 DIMENSIONAL TOLERANCES ARE:  
 FRACTIONS DECIMALS ANGLES  
 MILLIMETERS:  
 N/A ±.127 ±.5°  
 INCHES:  
 ±1/64 ±.005 ±.5°

CAD GENERATED DRAWING.  
 DO NOT MANUALLY UPDATE

 2119 FM 1626  
 MANCHACA TX. 78652  
 (512) 282-1590

APPROVALS	DATE
DRAWN	2/6/2018
CHECKED	
RESP ENG	
MFG ENG	
QUAL ENG	

**Exploded View - 610-PHO**  
**Standard 610 Pump**

NEXT ASSY	USED ON
APPLICATION	

MATERIAL **SEE NOTES**  
 FINISH **SEE NOTES**  
 DO NOT SCALE DRAWING

SIZE DWG. NO. REV.  
 A 610-PHO  
 SCALE CAD FILE: 610-PHO SHEET 2 OF 3

THE INFORMATION CONTAINED IN THIS DRAWING IS THE SOLE PROPERTY OF THE RANDOLPH AUSTIN CO.. ANY REPRODUCTION IN PART OR WHOLE WITHOUT THE WRITTEN PERMISSION OF THE RANDOLPH AUSTIN CO. IS PROHIBITED.

ITEM NO.	PART NUMBER	610-PH3/QTY.
1	61-0010	1
2	01-0113	2
3	01-0133	1
4	61-0050	1
5	00-0601	1
6	61-0140	3
7	61-0097	1
8	00-0532	1
9	61-0080	1

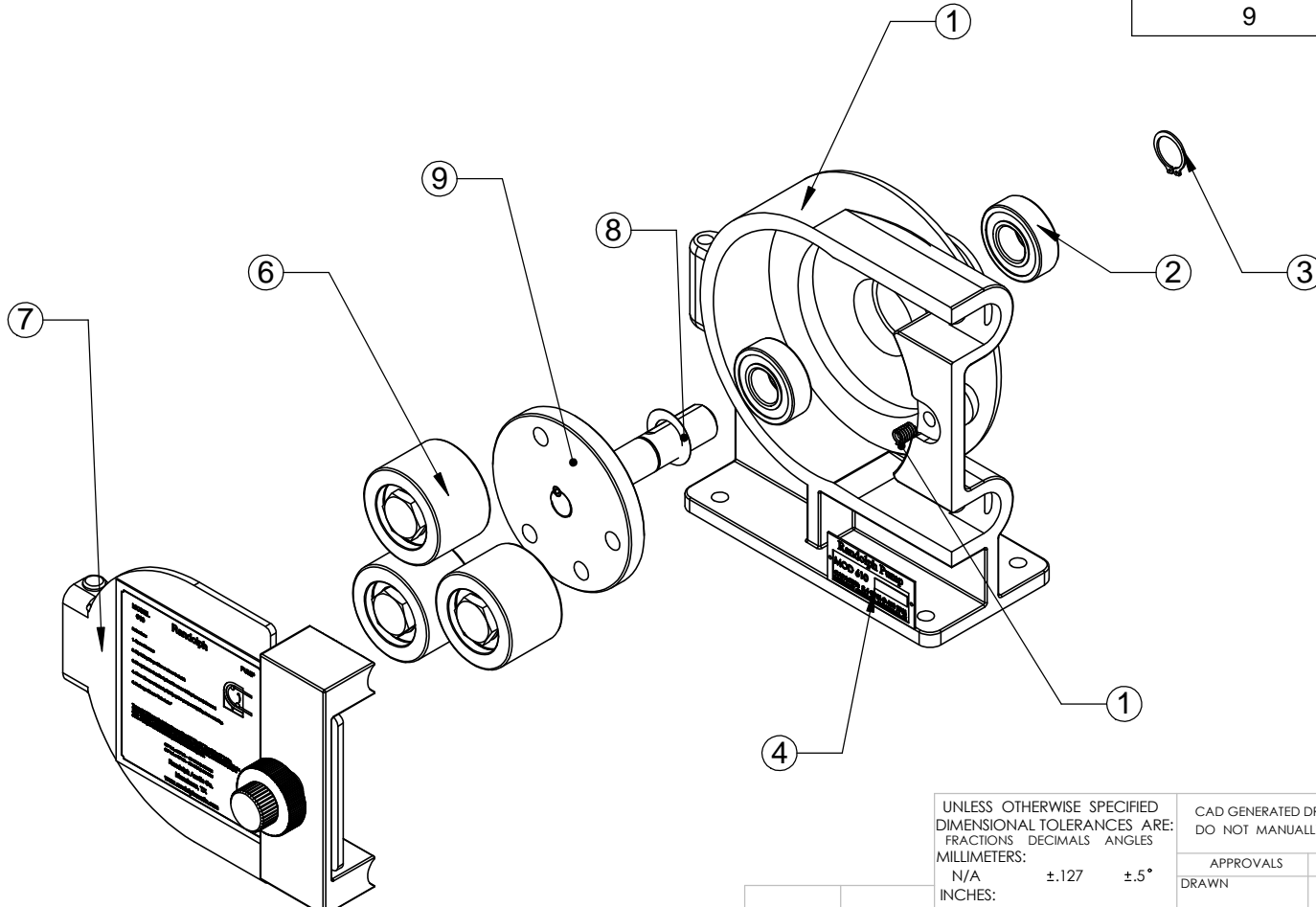

UNLESS OTHERWISE SPECIFIED  
 DIMENSIONAL TOLERANCES ARE:  
 FRACTIONS DECIMALS ANGLES  
 MILLIMETERS:  
 N/A ±.127 ±.5°  
 INCHES:  
 ±1/64 ±.005 ±.5°

CAD GENERATED DRAWING.  
 DO NOT MANUALLY UPDATE

 2119 FM 1626  
 MANCHACA TX. 78652  
 (512) 282-1590

NEXT ASSY	USED ON
APPLICATION	

MATERIAL **SEE NOTES**  
 FINISH **SEE NOTES**  
 DO NOT SCALE DRAWING

APPROVALS	DATE
DRAWN	2/6/2018
CHECKED	
RESP ENG	
MFG ENG	
QUAL ENG	

**Exploded view - 610-PH3**  
**3 Impeller pump assy**

SIZE	DWG. NO.	REV.
A	610-PH3	
SCALE	CAD FILE: 610-PHO	SHEET 3 OF 3