

Items Not Shown:

- 1) 05-0153: Qty 1, Plug,CPH7713, Explosion Proof
- 2) 05-0055: Qty 1, 5 ft of Line Cord, 14-3-SO
- 3) 00-0323: Qty 2, 1/2" Coupling
- 4) 00-0335: Qty 1, 5/8" Coupling
- 5) 00-0345: Qty 2, 3/4" Coupling
- 6) 00-0385: Qty 2, "Spyder" for coupling
- 7) 00-0411: Qty 1, 6" x 1/2 NPT
- 8) 00-0415: Qty 1, 90° x 1/2 NPT

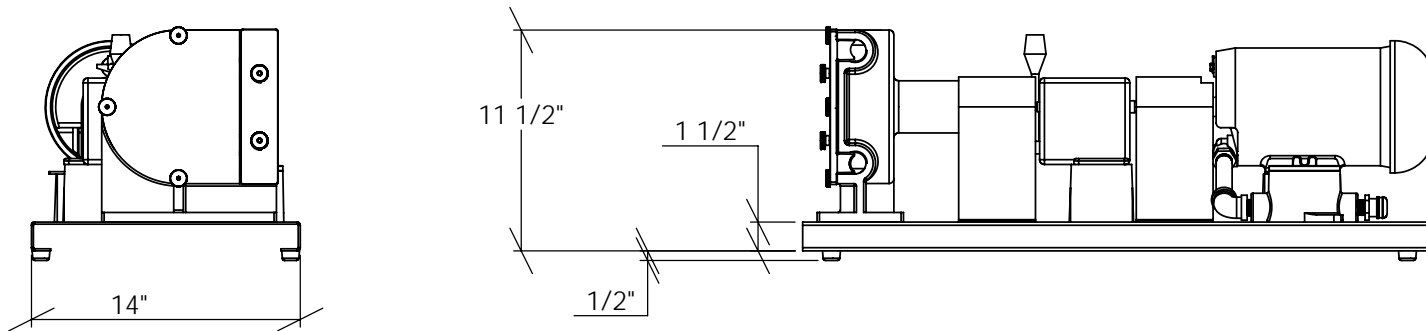

**PROPRIETARY AND CONFIDENTIAL**  
 THE INFORMATION CONTAINED IN THIS DRAWING IS THE SOLE PROPERTY OF Randolph Austin Company. ANY REPRODUCTION IN PART OR AS A WHOLE WITHOUT THE WRITTEN PERMISSION OF Randolph Austin Company IS PROHIBITED.

		DIMENSIONS ARE IN INCHES TOLERANCES: FRACTIONAL ± 1/64 ANGULAR: MACH ± 1° TWO PLACE DECIMAL ± .010 THREE PLACE DECIMAL ± .005		NAME	DATE	Randolph Austin Company
		MATERIAL --		DRAWN		
		FINISH --		CHECKED		
NEXT ASSY	USED ON			ENG APPR.		
APPLICATION		DO NOT SCALE DRAWING		MFG APPR.		
				Q.A.		SIZE <b>A</b> DWG. NO. 750-201 REV.
				COMMENTS:		
				SCALE:1:2	WEIGHT:	SHEET 1 OF 1