

		REVISIONS		
ZONE	REV.	DESCRIPTION	DATE	APPROVED
	A	Motor was 03-0363 is 03-0364	06/28/06	

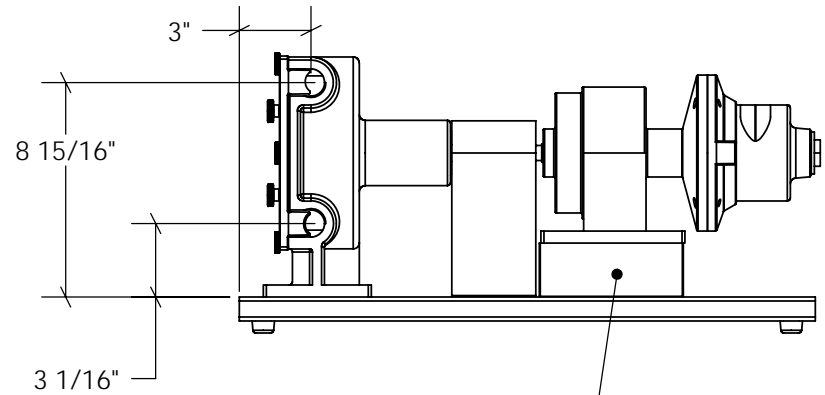

02-0489: Qty 2
Spacer

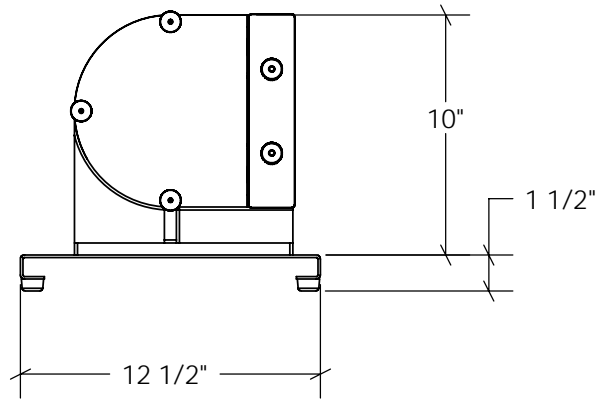
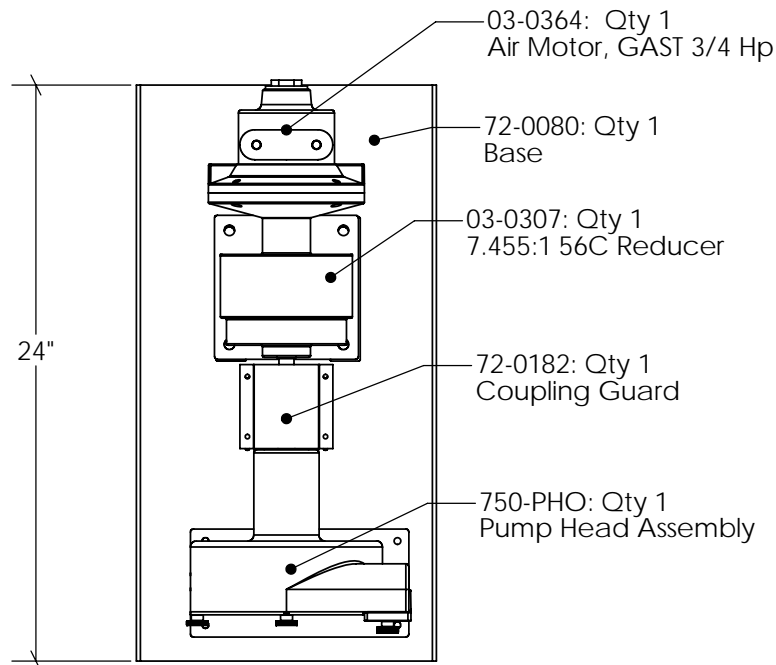

Bill Of Materials:
Items not Shown

Part #	Qty and Description
03-0378	Qty 1: Filter
03-0379	Qty 1: Regulator
00-0335	Qty 2: 5/8" Bore Coupling
00-0375	Qty 1: Elastomer, Coupling Spyder,

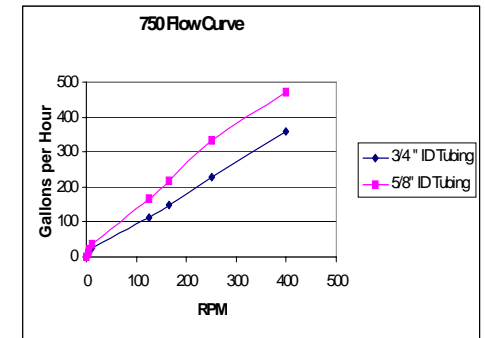

PROPRIETARY AND CONFIDENTIAL
THE INFORMATION CONTAINED IN THIS DRAWING IS THE SOLE PROPERTY OF Randolph Austin Company. ANY REPRODUCTION IN PART OR AS A WHOLE WITHOUT THE WRITTEN PERMISSION OF Randolph Austin Company IS PROHIBITED.

		DIMENSIONS ARE IN INCHES TOLERANCES: FRACTIONAL ± 1/64 ANGULAR: MACH ± 1 TWO PLACE DECIMAL ± .01 THREE PLACE DECIMAL ± .005		NAME	DATE	Randolph Austin Co
		MATERIAL	--	DRAWN		
		FINISH	--	CHECKED		750-455: Pump with Air motor Assy
				ENG APPR.		
NEXT ASSY	USED ON			MFG APPR.		
APPLICATION		DO NOT SCALE DRAWING		Q.A.		
				COMMENTS:		
SIZE	DWG. NO.			SCALE:1:1	WEIGHT:	
A	750-455					REV. A
						SHEET 1 OF 1