

81-0220; Cover Plate
Qty: 1

PROPRIETARY AND CONFIDENTIAL
 THE INFORMATION CONTAINED IN THIS DRAWING IS THE SOLE PROPERTY OF Randolph Austin Company. ANY REPRODUCTION IN PART OR AS A WHOLE WITHOUT THE WRITTEN PERMISSION OF Randolph Austin Company IS PROHIBITED.

		DIMENSIONS ARE IN INCHES		NAME	DATE
		TOLERANCES:		DRAWN	
		FRACTIONAL: $\pm 1/64$		CHECKED	
		ANGULAR: MACH ± 1		ENG APPR.	
		TWO PLACE DECIMAL $\pm .01$		MFG APPR.	
		THREE PLACE DECIMAL $\pm .005$		Q.A.	
		MATERIAL --		COMMENTS:	
NEXT ASSY	USED ON	FINISH --			
APPLICATION		DO NOT SCALE DRAWING			

Randolph Austin Co

M880-PHO
2 impeller - XP View

SIZE A	DWG. NO. M880-2-XP	REV. A
SCALE: 1:1	WEIGHT:	SHEET 1 OF 1

THE INFORMATION CONTAINED IN THIS DRAWING IS THE SOLE PROPERTY OF THE RANDOLPH AUSTIN CO., ANY REPRODUCTION IN PART OR WHOLE WITHOUT THE WRITTEN PERMISSION OF THE RANDOLPH AUSTIN CO. IS PROHIBITED.

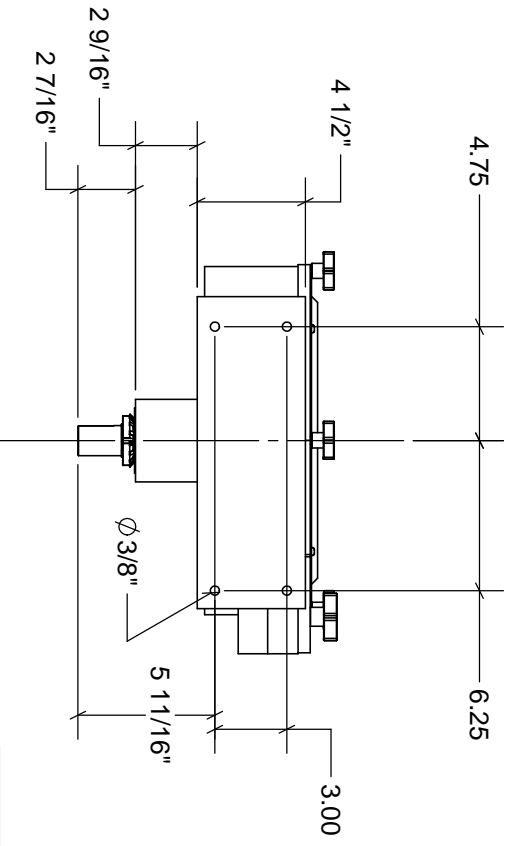
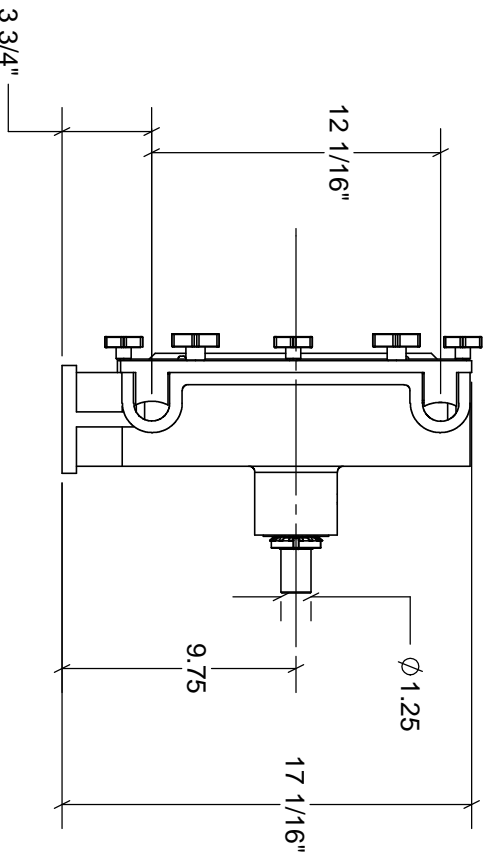
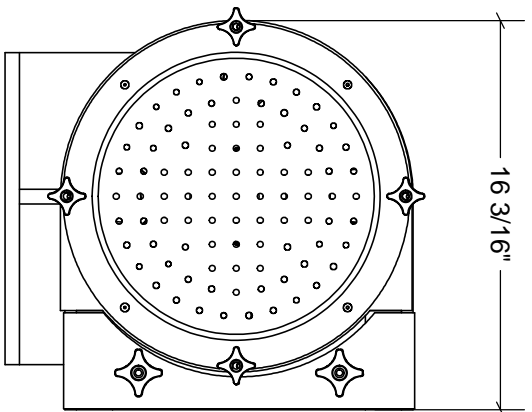

Shipping Weight 85 lbs

UNLESS OTHERWISE SPECIFIED
DIMENSIONAL TOLERANCES ARE:
FRACTIONS: DECIMALS: ANGLES:
MILLIMETERS: ±.1 ±1.0°
N/A ±.005 ±1.0°
INCHES: ±1/64

Randolph Austin Company
PO 988 2119 FM 1626 MANCHACA TX.

Mounting Dimensions
880 pump

APPROVALS	DATE	SIZE DWG. NO. 880-PHO-MD SCALE CAD FILE: REV.
DRAWN		
CHECKED		
RESP ENG		
FINISH	DO NOT SCALE DRAWING	QUAL ENG
NEXT ASSY	USED ON	
APPLICATION		

