

RPM -->	100	170	280
6.4 mm (.250")	646	1090	1861
8.0 mm (.312")	998	1699	2799

Flow in ml per minute with water after 20 minute break in period.
No, head pressure

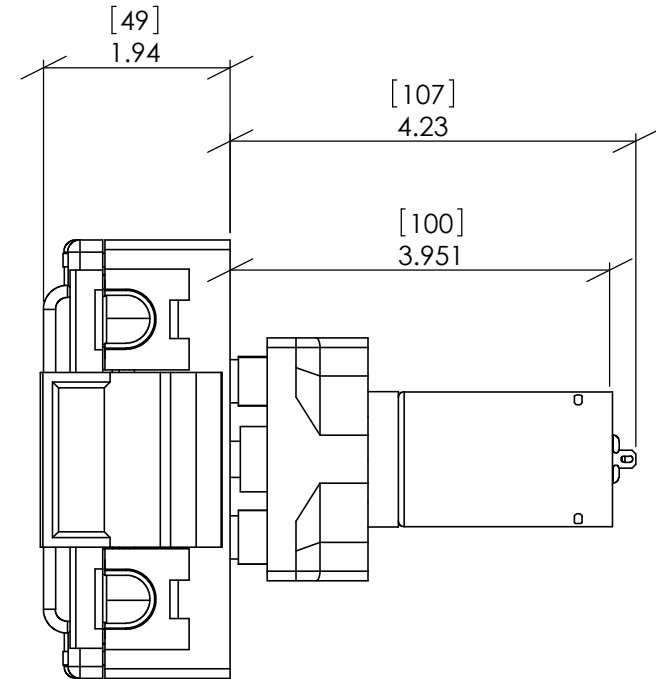
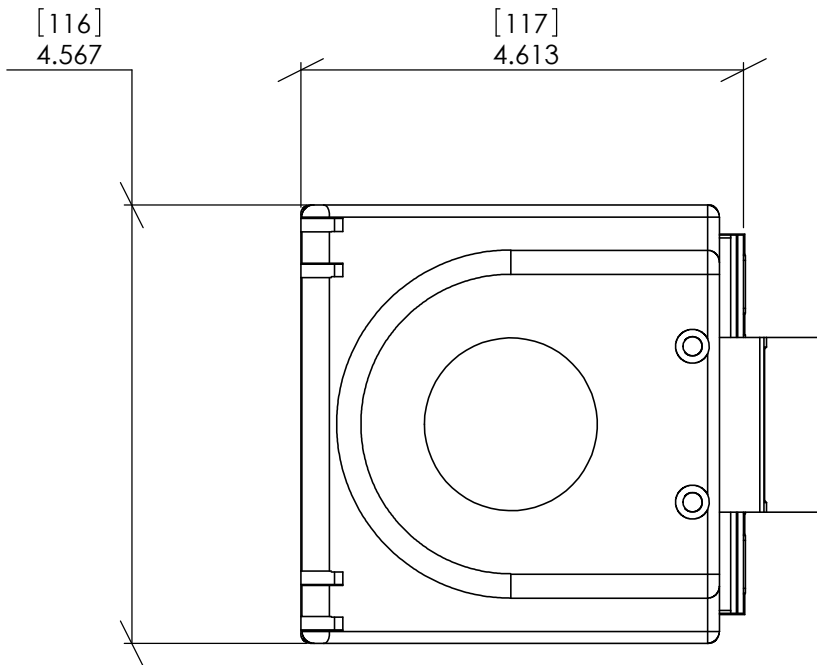
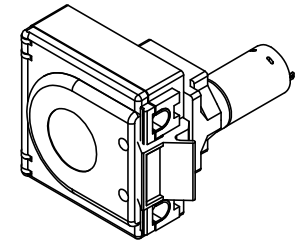

PROPRIETARY AND CONFIDENTIAL
THE INFORMATION CONTAINED IN THIS DRAWING IS THE SOLE PROPERTY OF Randolph Austin Company. ANY REPRODUCTION IN PART OR AS A WHOLE WITHOUT THE WRITTEN PERMISSION OF Randolph Austin Company IS PROHIBITED.

		DIMENSIONS ARE IN INCHES TOLERANCES: FRACTIONAL ± 1/64 ANGULAR: MACH ± 1° TWO PLACE DECIMAL ± .010 THREE PLACE DECIMAL ± .005		NAME	DATE	Randolph Austin Company	
		MATERIAL --		DRAWN		TP - 4000 OEM - DC Motor	
		FINISH --		CHECKED			
NEXT ASSY	USED ON			ENG APPR.			
APPLICATION		DO NOT SCALE DRAWING		MFG APPR.			
				Q.A.			
				COMMENTS:		SIZE A	DWG. NO. SETP4000-D2-XXX
						SCALE:1:2	WEIGHT:
						SHEET 1 OF 2	

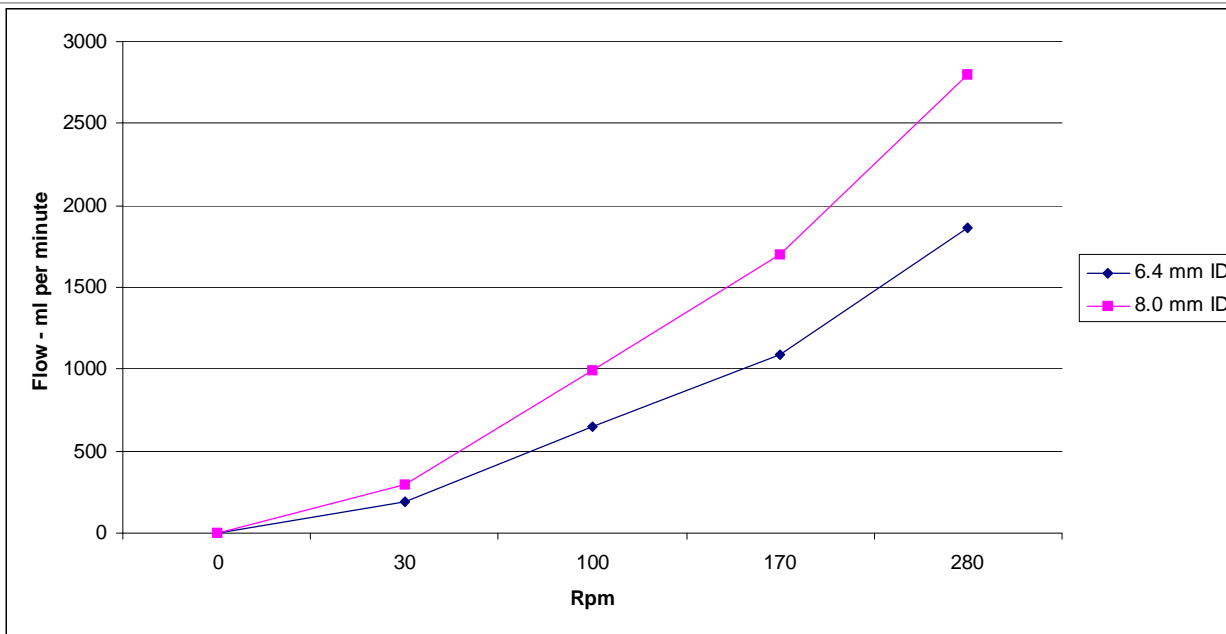

Model	RPM	Voltage	Running Amps, Std Motor	Max Amps, Std Motor	Watts	Motor Life Rating, *Continuous Hrs.	Pump Lift **H2O
SETP400-D2-100	100	24	0.5	1.1	30	5000	22.9' (7m)
SETP400-D2-170	170	24	0.5	1.1	30	5000	22.9' (7m)
SETP400-D2-280	280	24	0.5	1.1	30	5000	22.9' (7m)

* Standard Life expectancy of motor working at 100% power.

** Lifting distance will be affected by tubing material, and the viscosity of the fluid being pumped.

PROPRIETARY AND CONFIDENTIAL
 THE INFORMATION CONTAINED IN THIS DRAWING IS THE SOLE PROPERTY OF Randolph Austin Company. ANY REPRODUCTION IN PART OR AS A WHOLE WITHOUT THE WRITTEN PERMISSION OF Randolph Austin Company IS PROHIBITED.

		DIMENSIONS ARE IN INCHES TOLERANCES: FRACTIONAL ± 1/64 ANGULAR: MACH ± 1° TWO PLACE DECIMAL ± .010 THREE PLACE DECIMAL ± .005	NAME	DATE	Randolph Austin Company
			DRAWN		
			CHECKED		
			ENG APPR.		
			MFG APPR.		
		MATERIAL	--		
NEXT ASSY	USED ON	FINISH	--		
APPLICATION		DO NOT SCALE DRAWING			
		COMMENTS:			
SIZE	DWG. NO.			REV.	
A					
SCALE:1:2	WEIGHT:			SHEET 2 OF 2	